



Client \_\_\_\_\_ Quantity \_\_\_\_\_  
Project \_\_\_\_\_ Position \_\_\_\_\_

## FUN 700

**Model:** F70/70PCE/A

**Cod:** MP01012123003

### Technical data

<b>Modularity:</b>	On open cabinet
<b>Dimension (mm):</b>	700x700x850
<b>Total electric power (kW):</b>	10,4
<b>Electric power (V):</b>	380-415
<b>Ampere (A):</b>	24
<b>Phases:</b>	3N
<b>Cable section (mmq):</b>	5G4
<b>Frequency (Hz):</b>	50-60
<b>Net volume (m3):</b>	0,417
<b>Packing dimensions (mm):</b>	776x776x1180
<b>Gross weight (kg):</b>	57
<b>Gross volume (m3):</b>	0,711

### Features

<b>Working top:</b>	Made of AISI 304 stainless steel with a thickness of 10/10 mm
<b>Knobs:</b>	Knobs are made from a sturdy heat-resistant polymer blend and are equipped with liquid anti-leakage washer

Electric hob 4 burners on open cabinet Top made of AISI 304 stainless steel thickness 8/10; covering in AISI 304 stainless steel thickness 8/10; bottoms and internal parts in AISI 430 steel; internal reinforcements made of anti-corrosion material (aluminised sheet metal). Hob equipped with cast iron electric plates with stainless steel edge sealed to top. Each plate is controlled by a switch with 6 possible temperature adjustments and is equipped with indicator lights to show that electrical power is being provided and that the plates are working. Model with round plates Ø 220 mm. - 4 plates x 2.6 kW. Total power 10.4 kW Electrical power supply VAC 400 + 3N 50÷60 Hz. Set up on open cabinet.

### Technical draw

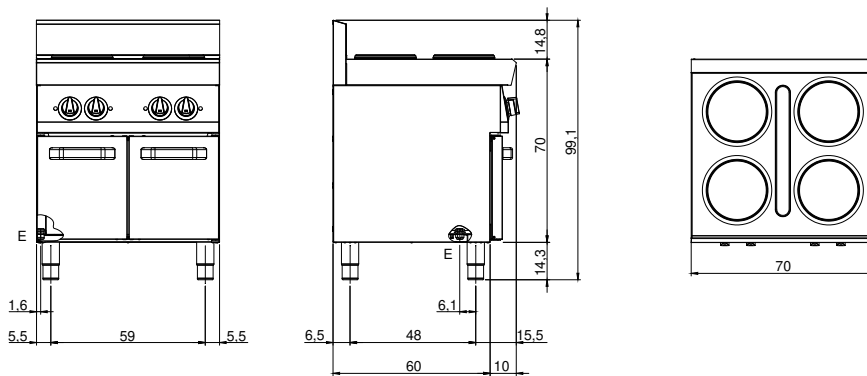

**E:** Electric power