

Client _____ Quantity _____

Project _____ Position _____

FUN 700

Model: F70/70PCEQ/T

Cod: MP01012123006



Technical data

Modularity:	Top
Dimension (mm):	700x700x300
Total electric power (kW):	10,4
Electric power (V):	380-415
Ampere (A):	24
Phases:	3N
Cable section (mmq):	5G4
Frequency (Hz):	50-60
Net volume (m3):	0,147
Packing dimensions (mm):	776x776x636
Gross weight (kg):	53
Gross volume (m3):	0,383

Features

Working top:	Made of AISI 304 stainless steel with a thickness of 10/10 mm
Knobs:	Knobs are made from a sturdy heat-resistant polymer blend and are equipped with liquid anti-leakage washer

Electric hob 4 square plates top version. Top made of AISI 304 stainless steel thickness 8/10; covering in AISI 304 stainless steel thickness 8/10; bottoms and internal parts in AISI 430 steel; internal reinforcements made of anti-corrosion material (aluminised sheet metal). Hob equipped with cast iron electric plates with stainless steel edge sealed to top. Each plate is controlled by a switch with 6 possible temperature adjustments and is equipped with indicator lights to show that electrical power is being provided and that the plates are working. Model with square plates 220x220 mm. - 4 plates x 2.6 kW. Total power 10.4 kW Electrical power supply VAC 400 + 3N 50÷60 Hz. Can be set up on bridge system, on open cabinet or with doors.

Technical draw

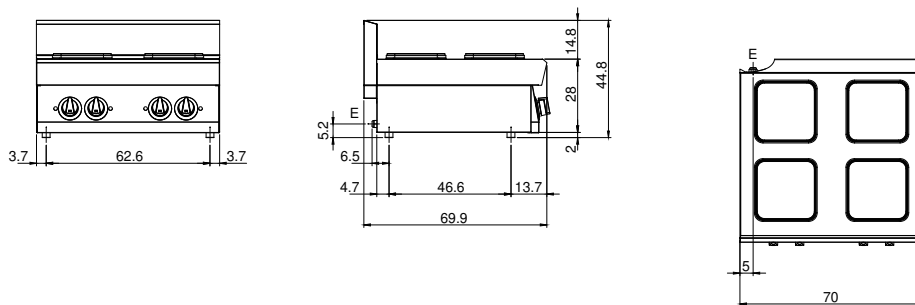

E: Electric power