

Client \_\_\_\_\_ Quantity \_\_\_\_\_

Project \_\_\_\_\_ Position \_\_\_\_\_

## FUN 700

Model: F70/40PCEQ/P

Cod: MP01012123010

### Technical data

Modularity:	On cabinet with door
Dimension (mm):	400x700x850
Total electric power (kW):	5,2
Electric power (V):	380-415
Ampere (A):	12
Phases:	3N
Cable section (mmq):	5G1,5
Frequency (Hz):	50-60
Net volume (m3):	0,238
Packing dimensions (mm):	477x776x1147
Gross weight (kg):	45
Gross volume (m3):	0,425

### Features

Working top:	Made of AISI 304 stainless steel with a thickness of 10/10 mm
Knobs:	Knobs are made from a sturdy heat-resistant polymer blend and are equipped with liquid anti-leakage washer
Handles:	Brushed aluminum finish

Electric hob 2 plates on cabinet with door. Top made of AISI 304 stainless steel thickness 8/10; covering in AISI 304 stainless steel thickness 8/10; bottoms and internal parts in AISI 430 steel; internal reinforcements made of anti-corrosion material (aluminised sheet metal). Hob equipped with cast iron electric plates with stainless steel edge sealed to top. Each plate is controlled by a switch with 6 possible temperature adjustments and is equipped with indicator lights to show that electrical power is being provided and that the plates are working. Model with square plates 220x220 mm. - 2 plates x 2.6 kW. Total power 5.2 kW Electrical power supply VAC 400 + 3N 50÷60 Hz. Set up on open cabinet.

### Technical draw

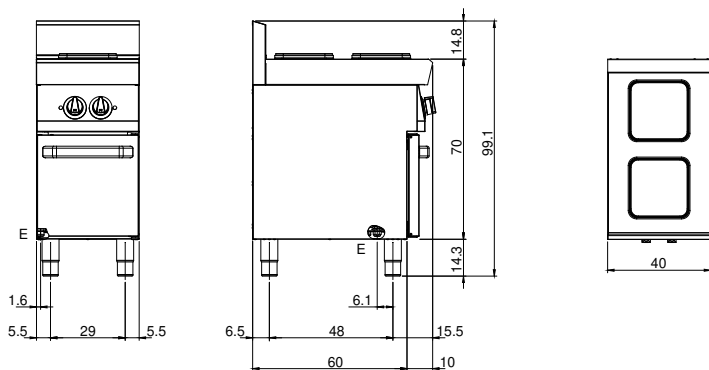

E: Electric power