

Client _____ Quantity _____
 Project _____ Position _____

FUN 700

Model: F70/40PVE/T

Cod: MP01092123000



Technical data

Modularity:	Top
Dimension (mm):	400x700x300
Total electric power (kW):	5
Electric power (V):	380-415
Ampere (A):	11,5
Phases:	3N
Cable section (mmq):	5G2,5
Frequency (Hz):	50-60
Net volume (m3):	0,084
Packing dimensions (mm):	477x776x612
Gross weight (kg):	22
Gross volume (m3):	0,227

Features

Working top:	Made of AISI 304 stainless steel with a thickness of 10/10 mm
Knobs:	Knobs are made from a sturdy heat-resistant polymer blend and are equipped with liquid anti-leakage washer

Electric pyroceram hob top version. Top made of AISI 304 stainless steel thickness 8/10; covering in AISI 304 stainless steel thickness 8/10; bottoms and internal parts in AISI 430 steel; internal reinforcements made of anti-corrosion material (aluminised sheet metal). Spacious hermetic hob, easy to clean, featuring independent cooking zones and gradual temperature adjustment. The cooking zones are highly flexible. They reach operating temperature quickly and are equipped with a device against overheating. - 1 plate x 2.1 kW and 1 x 2.5 - Total power 4.6 kW Electrical power supply VAC 400 + 3N 50±60 Hz. Can be set up on bridge system, or on neutral base with optional doors

Technical draw

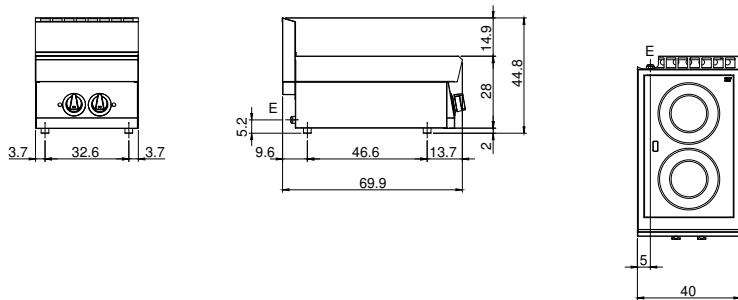

E: Electric power