



Client _____ Quantity _____
 Project _____ Position _____

FUN 700

Model: F70/70FTG/LR/P

Cod: MP01372113026

Market: Extra UE

Technical data

Modularity:	On cabinet with doors
Dimension (mm):	700x700x850
Total gas power (Kcal/h):	9803
Total gas power (kW):	11,4
Cooking zone dimensions 1 (LxD mm):	696x520
Gas connection:	1/2"
Net volume (m3):	0,417
Packing dimensions (mm):	776x776x1180
Gross weight (kg):	92
Gross volume (m3):	0,711

Features

Working top:	Made of AISI 304 stainless steel with a thickness of 10/10 mm
Material of plate:	Mild steel
Knobs:	Knobs are made from a sturdy heat-resistant polymer blend and are equipped with liquid anti-leakage washer
Handles:	Brushed aluminum finish
Plate:	In mild steel
Kit Gas:	Natural gas conversion kit 30/50 m/bar (tested with natural gas G20)

Gas griddle plate 2/3 Smooth 1/3 grooved on cabinet with doors. Top made of AISI 304 stainless steel thickness 8/10; covering in AISI 304 stainless steel thickness 8/10; external reinforcements made of anti-corrosion material (aluminised sheet metal); bottoms and internal parts in AISI 430 steel; flue cover in enamelled steel. Equipped with two independent cooking zones. Provided with front groove, extractable drawer for grease collection and splash guard on three sides. Equipped with burners with pilot burners with piezoelectric ignition. Gas supplied by means of safety valve with thermocouple. - 2 burners x 5.7 kW Total power 11.4 kW Plate dimensions 695x550 mm.

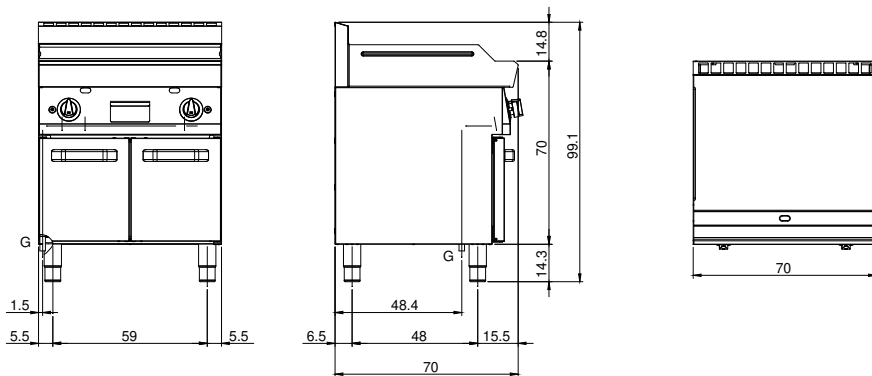
Technical draw

G: Gas connection 1/2"