



Client \_\_\_\_\_ Quantity \_\_\_\_\_

Project \_\_\_\_\_ Position \_\_\_\_\_

## FUN 700

**Model:** F70/40FTE/CR/P

**Cod:** MP01372123023

### Technical data

<b>Modularity:</b>	On cabinet with door
<b>Dimension (mm):</b>	400x700x850
<b>Total electric power (kW):</b>	4,5
<b>Cooking zone dimensions 1 (LxD mm):</b>	396x520
<b>Electric power (V):</b>	380-415
<b>Ampere (A):</b>	7
<b>Phases:</b>	3N
<b>Cable section (mmq):</b>	5G1,5
<b>Frequency (Hz):</b>	50-60
<b>Net volume (m3):</b>	0,238
<b>Packing dimensions (mm):</b>	477x776x1147
<b>Gross weight (kg):</b>	60
<b>Gross volume (m3):</b>	0,425

### Features

<b>Working top:</b>	Made of AISI 304 stainless steel with a thickness of 10/10 mm
<b>Material of plate:</b>	Polished chrome
<b>Plate finish:</b>	Ribbed
<b>Knobs:</b>	Knobs are made from a sturdy heat-resistant polymer blend and are equipped with liquid anti-leakage washer
<b>Handles:</b>	Brushed aluminum finish
<b>Plate:</b>	Polished chromed plate

Fry-top elettrico con piastra rigata cromata lucida su armadio con porte. Piano costruito in acciaio inox AISI 304 di spessore 8/10; involucro in acciaio inox AISI 304 spessore 8/10; rinforzi esterni eseguiti in materiale anticorrosione (lamiera alluminata); fondi e parti interne in acciaio; copertura camino in acciaio smaltato. Piastra in acciaio cromato ad alta conducibilità termica per una distribuzione uniforme della temperatura. Provvisto di canaletta anteriore, cassetto estraibile per la raccolta dei grassi residui. Zona di cottura è dotata di 3 resistenze corazzate e regolate da termostato con campo di utilizzo da 50° a 300° C. Termostato di sicurezza e lampade spia di segnalazione del corretto funzionamento. Nr. 3 resistenze x 1,5 kW. Potenza totale 4,5 kW. Dimensioni piastra di cottura mm. 395x550. Alimentazione elettrica VAC 400+3N 50÷60 Hz. Allestimento su armadio aperto.

### Technical draw

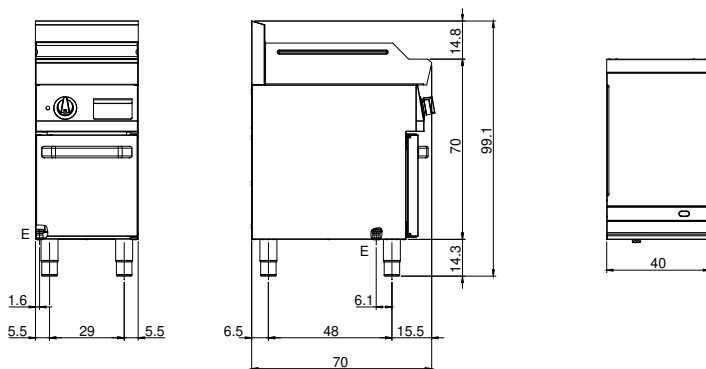

E: Electric power