



Client _____ Quantity _____

Project _____ Position _____

FUN 700

Model: F70/70FTE/LR/P

Cod: MP01372123026

Market: Extra UE

Technical data

Modularity:	On cabinet with doors
Dimension (mm):	700x700x850
Total electric power (kW):	9
Cooking zone dimensions 1 (LxD mm):	696x520
Electric power (V):	380-415
Ampere (A):	14
Phases:	3N
Cable section (mmq):	5G2,5
Frequency (Hz):	50-60
Net volume (m3):	0,417
Packing dimensions (mm):	776x776x1180
Gross weight (kg):	94
Gross volume (m3):	0,711

Features

Working top:	Made of AISI 304 stainless steel with a thickness of 10/10 mm
Material of plate:	Mild steel
Knobs:	Knobs are made from a sturdy heat-resistant polymer blend and are equipped with liquid anti-leakage washer
Handles:	Brushed aluminum finish
Plate:	In mild steel

Electric griddle plate 2/3 Smooth 1/3 grooved on cabinet with doors. Top made of AISI 304 stainless steel thickness 8/10; covering in AISI 304 stainless steel thickness 8/10; external reinforcements made of anti-corrosion material (aluminised sheet metal); bottoms and internal parts in AISI 430 steel; flue cover in enamelled steel. Equipped with two independent cooking zones. Provided with front groove, extractable drawer for grease collection and splash guard on three sides. Cooking zone equipped with 3 heating elements which are thermostat controlled in a range of use from 50° to 300° C. Safety thermostat and indicator lights to show correct operation. 6 plates x 1.5 kW. Total power 9 kW. Cooking plate dimensions 695x550 mm. Electrical power supply VAC 400 + 3N 50÷60 Hz.

Technical draw

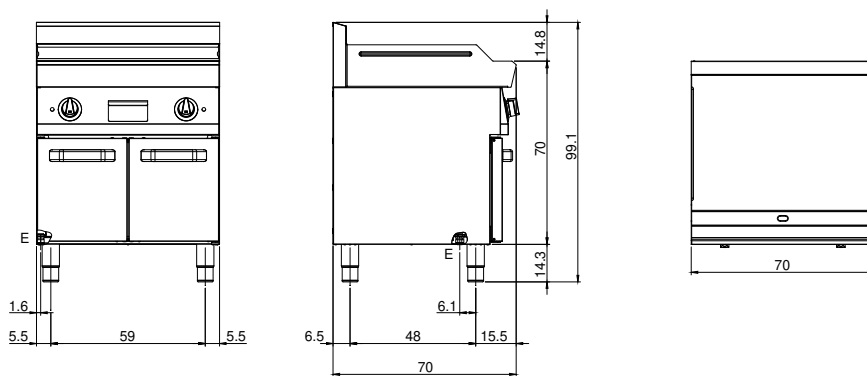

E: Electric power