



Client _____ Quantity _____
 Project _____ Position _____

FUN 700

Model: F70/40GRE/P

Cod: MP01412123005

Technical data

Modularity:	On cabinet with door
Dimension (mm):	400x700x850
Total electric power (kW):	4,08
Cooking zone dimensions 1 (LxD mm):	265x405
Electric power (V):	380-415
Ampere (A):	6,5
Phases:	3N
Cable section (mmq):	5G1,5
Frequency (Hz):	50-60
Net volume (m3):	0,238
Packing dimensions (mm):	477x776x1147
Gross weight (kg):	63
Gross volume (m3):	0,425

Features

Working top:	Made of AISI 304 stainless steel with a thickness of 10/10 mm
Knobs:	Knobs are made from a sturdy heat-resistant polymer blend and are equipped with liquid anti-leakage washer
Handles:	Brushed aluminum finish

Electric griddle on cabinet with door. Top made of AISI 304 stainless steel thickness 8/10; covering in AISI 304 stainless steel thickness 8/10; external reinforcements made of anti-corrosion material (aluminised sheet metal); bottoms and internal parts in AISI 430 steel; flue cover in enamelled steel. Provided with front groove, extractable drawer for grease collection and splash guard on three sides. Cooking zone equipped with 3 heating elements which are thermostat controlled in a range of use from 50° to 300° C. Safety thermostat and indicator lights to show correct operation. Total power 4.08 kW. Cooking plate dimensions 395x550 mm. Electrical power supply VAC 400 + 3N 50÷60 Hz.

Technical draw

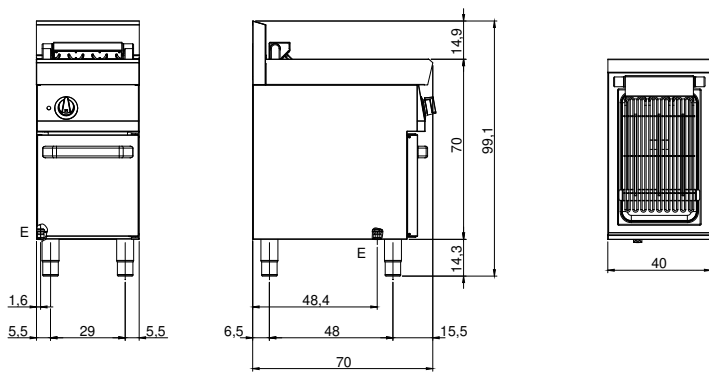

E: Electric power